

OPERATORS'

GRAND CUT 65 CNC AIR PLASMA CUTTER

IMPORTANT: Read this Owner's Manual Completely before attempting to use this equipment. Save this manual and keep it handy for quick reference. Pay particular attention to the safety instructions we have provided for your protection. Contact your distributor if you do not fully understand this manual.

CONTENT

<i>§1 Safety</i>	2
<i>§2 Overview</i>	5
§2.1 Features	5
§2.2 Working Principle	5
§2.3 Technical Data	6
§2.4 Duty Cycle and Over-heat	7
<i>§3 Panel Functions & Descriptions</i>	8
§3.1 Front and rear panel layout of cutting machine	8
§3.2 Control panel of cutting machine	9
§3.2.1 Panel introduction	9
§3.2.2 Display introduction	10
§3.2.3 Language selection interface	12
<i>§4 Installation</i>	13
§4.1 Unpacking	13
§4.2 Input Power Connections	13
§4.3 Gas Connections	14
<i>§5 Operation</i>	15
§5.1 Cutting Preparation	15
§5.2 Cutting Operation	15
§5.3 About the CUT voltage divider	17
§5.4 Operation Environment	20
§5.5 Operation Notices	20
<i>§6 Basic Trouble Shooting</i>	21
§6.1 Basic Troubleshooting Guide	21
§6.1.1 Basic troubles	21
§6.1.2 Pilot arc troubles	22
§6.1.3 Cutting troubles	23

§1 Safety

Notice: The instructions are for reference only. The manufacturer reserves the right to explain the differences between the description and the product due to product changes and upgrades!

Important Safety Precautions: Operation and maintenance of plasma ARC equipment can be dangerous to your health.

- Plasma arc cutting produces intense electric and magnetic emissions that may interfere with the proper function of cardiac pacemakers, hearing aids, or other electronic health equipment. Persons who work near plasma arc cutting applications should consult their medical health qualified technician and the manufacturer of the health equipment to determine whether a hazard exists.
- To prevent possible injury, read, understand and follow all warnings, safety precautions and instructions before using the equipment.



GASES AND FUMES

Gases and fumes produced during the plasma cutting process can be dangerous and hazardous to your health.

- Keep all fumes and gases from the breathing area. Keep your head out of the cutting fume plume.
- Use an air-supplied respirator if ventilation is not adequate to remove all fumes and gases.
- The kinds of fumes and gases from the plasma arc depend on the kind of metal being used, coatings on the metal, and the different processes. You must be very careful when cutting or cutting any metals which may contain one or more of the following:

Antimony	Chromium	Mercury	Beryllium
Arsenic	Cobalt	Nickel	Lead
Barium	Copper	Selenium	Silver
Cadmium	Manganese	Vanadium	

Always read the Material Safety Data Sheets (MSDS) that should be supplied with the material you are using.

These MSDSs will give you the information regarding the kind and amount of fumes and gases that may be dangerous to your health.

- Use special equipment, such as water or down draft cutting tables, to capture fumes and gases.
- Do not use the plasma torch in an area where combustible or explosive gases or materials are located.
- Phosgene, a toxic gas, is generated from the vapors of chlorinated solvents and cleansers. Remove all sources of these vapors.



ELECTRIC SHOCK

Electric Shock can injure or kill. The plasma arc process uses and produces high voltage electrical energy. This electric energy can cause severe or fatal shock to the operator or others in the workplace.

- Never touch any parts that are electrically “live” or “hot.”
- Wear dry gloves and clothing. Insulate yourself from the work piece or other parts of the cutting circuit.
- Repair or replace all worn or damaged parts.
- Extra care must be taken when the workplace is moist or damp.
- Disconnect power source before performing any service or repairs.
- Read and follow all the instructions in the Operating Manual.



FIRE AND EXPLOSION

Fire and explosion can be caused by hot slag, sparks, or the plasma arc.

- Be sure there is no combustible or flammable material in the workplace. Any



material that cannot be removed must be protected.

- Ventilate all flammable or explosive vapors from the workplace.
- Do not cut or weld on containers that may have held combustibles.
- Provide a fire watch when working in an area where fire hazards may exist.
- Hydrogen gas may be formed and trapped under aluminum workpieces when they are cut underwater or while using a water table. DO NOT cut aluminum alloys underwater or on a water table unless the hydrogen gas can be eliminated or dissipated. Trapped hydrogen gas that is ignited will cause an explosion.



NOISE

Noise can cause permanent hearing loss. Plasma arc processes can cause noise levels to exceed safe limits. You must protect your ears from loud noise to prevent permanent loss of hearing.

- To protect your hearing from loud noise, wear protective ear plugs and/or ear muffs. Protect others in the workplace.
- Noise levels should be measured to be sure the decibels (sound) do not exceed safe levels.

PLASMA ARC RAYS

Plasma Arc Rays can injure your eyes and burn your skin. The plasma arc process produces very bright ultra violet and infra red light. These arc rays will damage your eyes and burn your skin if you are not properly protected.

- To protect your eyes, always wear a cutting helmet or shield. Also always wear safety glasses with side shields, goggles or other protective eye wear.
- Wear cutting gloves and suitable clothing to protect your skin from the arc rays and sparks.
- Keep helmet and safety glasses in good condition. Replace lenses when cracked, chipped or dirty.
- Protect others in the work area from the arc rays. Use protective booths, screens or

shields.

§2 Overview

§2.1 Features

1. New panel design: More trendy and humanized.
2. LCD screen for accurate setting & feedback of cutting output.
3. With CNC interface, it can synchronize with CNC machine tools.
4. IGBT parallel balanced current technology and digital control technology.
5. Wider input voltage flexibility provides peak performance power under variable conditions ($\pm 10\%$) for steady cuts.
6. EMI filter restrains the EMI transmission of the power.
7. Starts without high-frequency so it will not interfere with controls or computers.
8. Pilot Arc Controller increases cutting capabilities and speeds, and improves tip life. So it can be applied to cut netlike workpiece.
9. Various protective and alarm functions for pressure, tip, over-temperature and over-current allow faster troubleshooting, eliminating unnecessary downtime.
10. Back striking tip and electrode ensure the velocity of striking and the quality of arc, and extend the life of them.

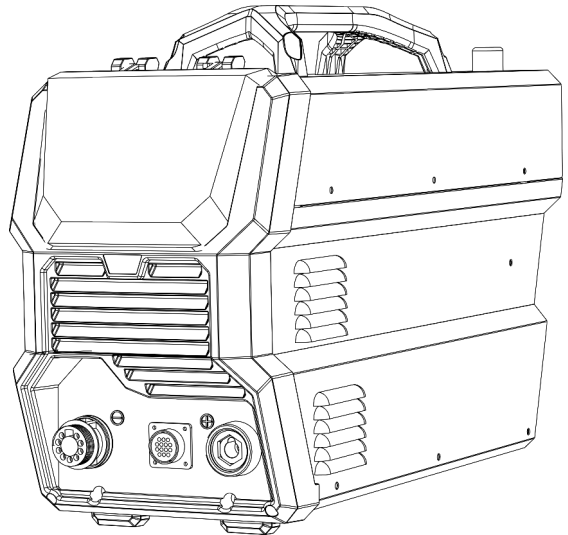

§2.2 Working Principle

The working principle of CUT Air Plasma Cutting Machine is shown as the following figure. Three-phase 400V work frequency AC is rectified into DC, then it is converted to medium frequency AC by inverter device (discrete IGBT), after reducing voltage by medium transformer (the main transformer) and rectified by medium frequency rectifier (fast recovery diode), and is outputted by inductance filtering. The circuit adopts current

feedback control technology to insure current output stably. Meanwhile, the cutting current parameter can be adjusted continuously and steplessly to meet with the requirements of cutting craft.

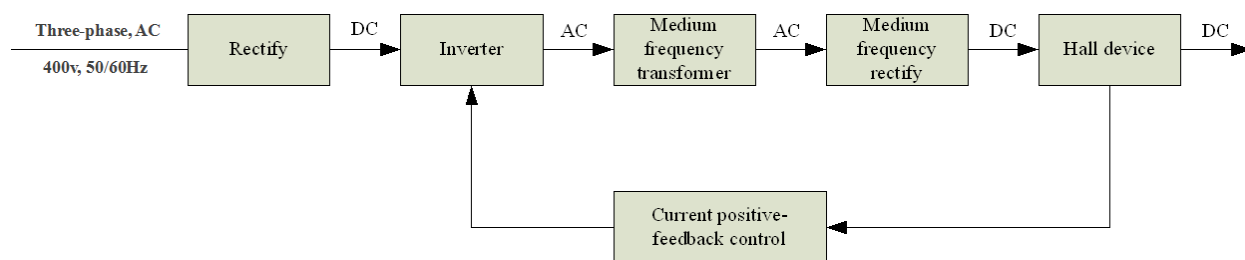

§2.3 Technical Data

Models		GRAND CUT 65 CNC
Parameters		
Rated input voltage (V)		3-400±10%
Frequency (HZ)		50/60
Rated input current (A)		16.5
Rated input power (kVA)		11.3
Cutting current adjustment range (A)		20~65
No-load voltage (V)		300
Duty cycle (40°C 10minutes)		100% 65A
Severance Cut for Carbon Steel (mm)		≤35
Optimal cutting thickness (mm)	Carbon steel	≤25
	Stainless steel	≤ 25
	Aluminum	≤ 20
	Cuprum	≤ 14
Dimensions (mm)		600*260*440
Protection class		IP21S
Circuit breaker		LW31-32B-4AB-04/2
Net weight (kg)		19.0
Cooling method		AF

Note: The above parameters are subject to change with the improvement of machines.

§2.4 Duty Cycle and Over-heat

The letter “X” stands for Duty Cycle, which is defined as the portion of the time a cutting machine can cut at maximum rated output current within a 10-minute cycle.

If the cutting machine is operated beyond the rated duty-cycle, the IGBT heat sensor will send a signal to the cutting machine control unit to switch the output cutting current OFF and the error code is displayed on the screen.

In that case, the machine should not be operated for 10~15 minutes to cool down with the fan running. When operating the machine again, the cutting output current or the duty cycle should be reduced.

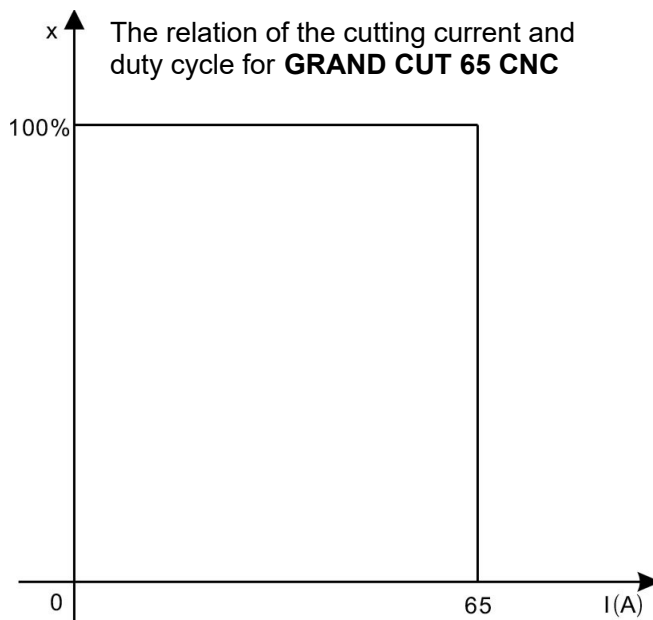

§3 Panel Functions & Descriptions

§3.1 Front and rear panel layout of cutting machine

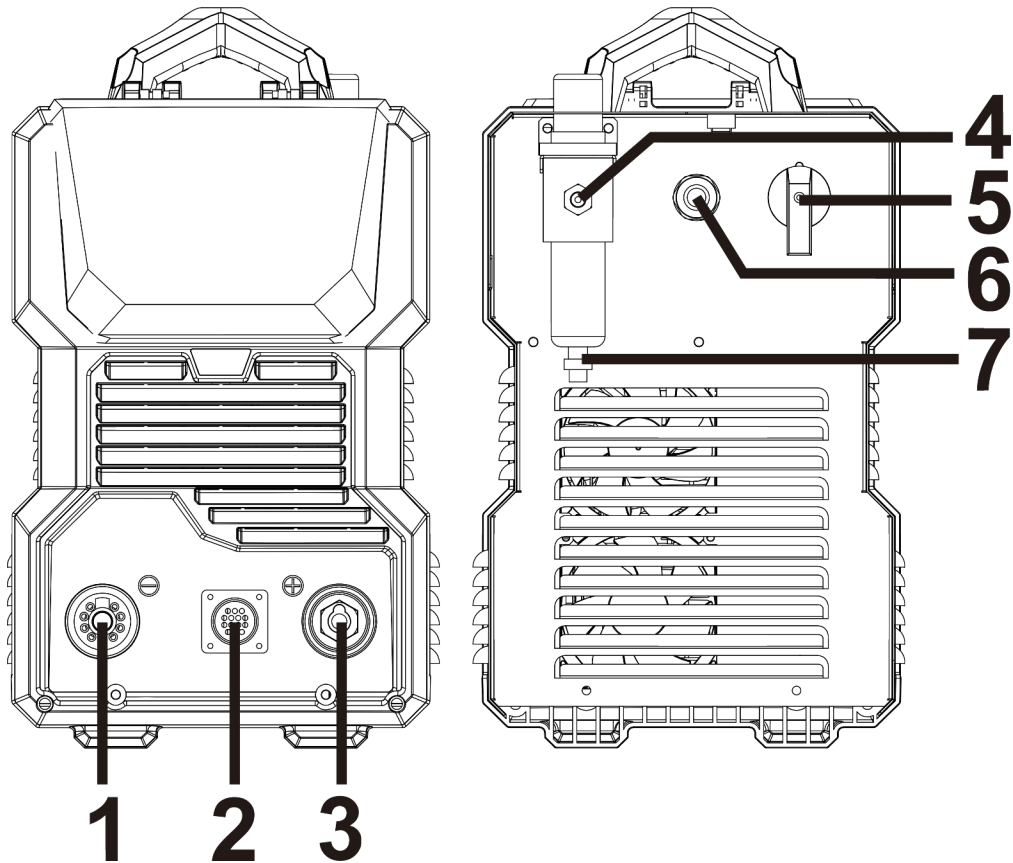

1. Plasma Torch Euro/ Central Connector.
2. CNC Interface Connection Port.
3. Earth Lead Connection Socket.
4. Compressed Air Inlet.
5. Power Switch: Turn on or off the power source.
6. Power cable: Connected to the appropriate power supply.
7. Air Filter Condensate Drain Tube.

§3.2 Control panel of cutting machine

§3.2.1 Panel introduction

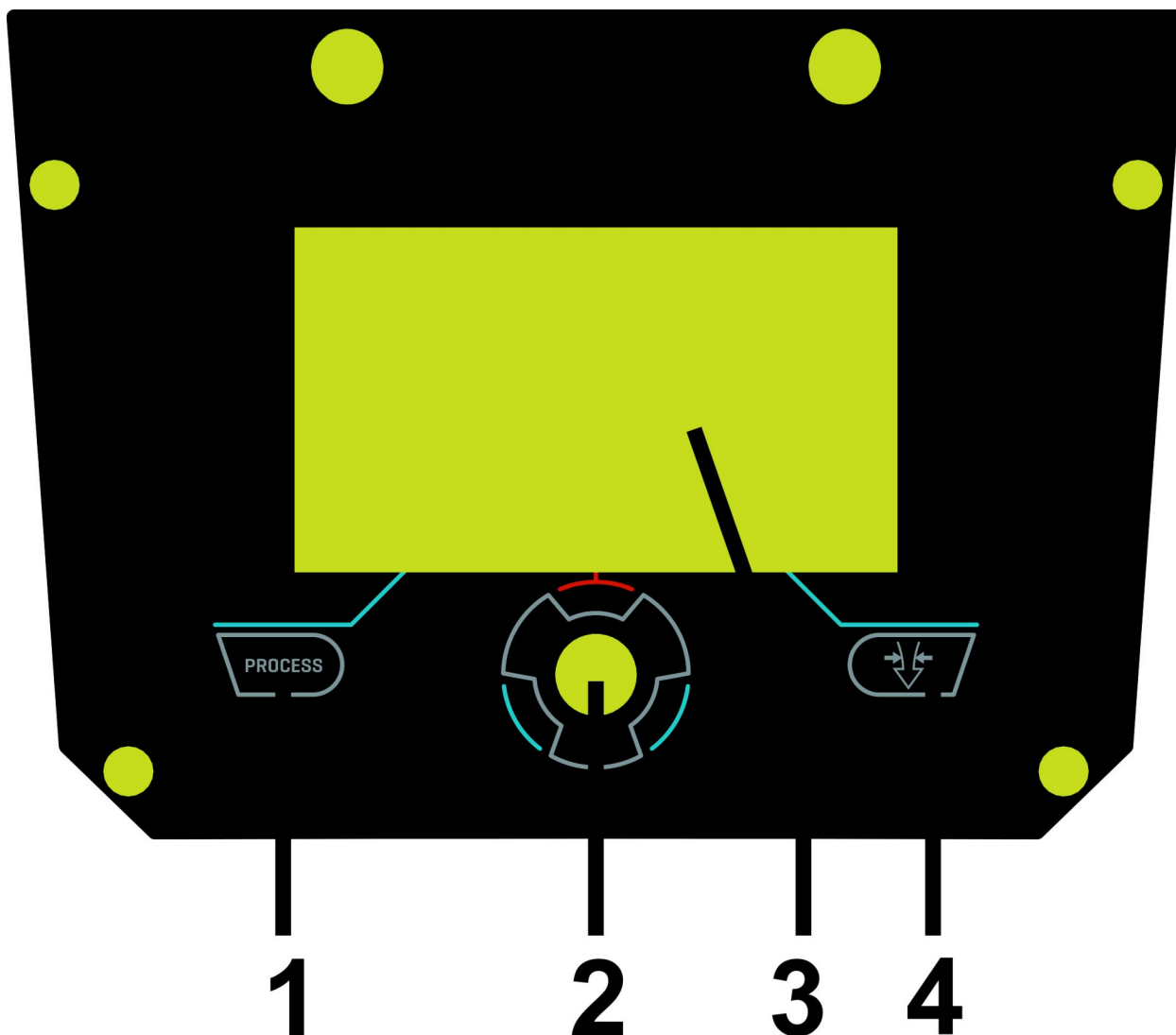

1. **Cutting mode button:** Press the button to select Standard cutting, Grid cutting and Gouging mode.
2. **Cutting current knob:** counterclockwise rotation reduces the current and clockwise rotation increases the current.
3. **Screen:** It displays cutting current, cutting mode and error codes.
4. **Air check button:** Press the button, if the machine is not connected to the gas line or the air pressure is low, the screen will display “E12 Lack of gas”.

§3.2.2 Display introduction

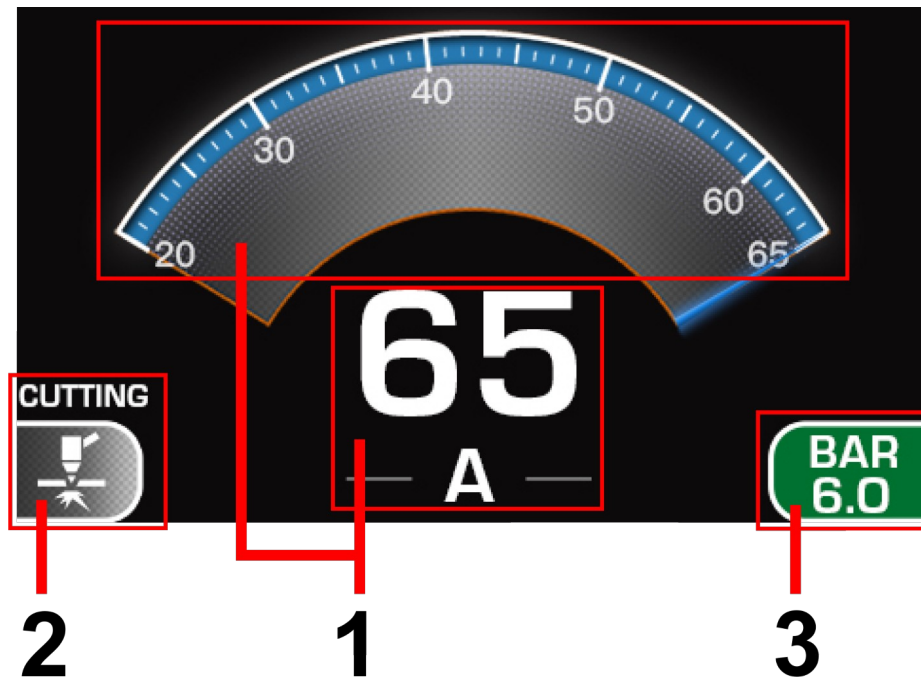

1. **Current display:** This is current display. Adjust it by the knob. Unit: A. the range of adjustment is 20~65A.
 2. **Cutting mode display:** This will display the cutting mode currently in use. *
 3. **Air check display:** This will display air pressure.*
- * Denotes more detailed explanation of function to follow.

Further Controls Explained

Cutting mode display (2)

Press the cutting mode button to select Standard cutting, Grid cutting and Gouging mode.



Standard Cutting

Similar to the grid cutting mode, the difference is that the arc breaks immediately

when the cutting torch nozzle leaves the workpiece surface.



Grid Cutting

As long as the cutting torch switch is pressed down, the arc will form. When the cutting torch leaves the workpiece surface, the arc will still exist. This function is used for continuous cutting for workpiece.



Gouging

Air gouging can work on any conductive metal, including low carbon steel, stainless steel, aluminum, and copper. Operators only need a little practice can planing a smooth, clean and consistent planer slot. In addition, air gouging can reduce the noise level in the work environment and the amount of debris.

Air gouging manual operation, but also can be configured semi-automatic gouging of auxiliary equipment. In addition, can also be in CNC controller for automatic air gouging cutting bed.

Air check display (3)

Press the air check key to check whether the air passage is smooth. If the machine is working properly, the screen will display the air pressure value normally, as shown in the figure below:



If the machine is not ventilated or the air path is not smooth and the air pressure is too low, it will cause the machine to alarm and display “E12 Lack of gas”, as shown in the figure below:



§3.2.3 Language selection interface



Press the cutting mode button and hold it for 3s to enter the language selection interface. Here you can select the language through the knob.

§4 Installation

§4.1 Unpacking

Use the packing lists to identify and account for each item.

1. Inspect each item for possible shipping damage. If damage is evident, contact your distributor and/or shipping company before proceeding with the installation.
2. When using forklift, its arm length must be long enough to reach the outside so as to ensure lifting safely.
3. The movement may bring the potential danger or substantive hazard, so please make sure that the machine is on the safe position before using.

§4.2 Input Power Connections

Supply input connection of CUT CNC power is shown as the Figure:

Separately connect the 3 pcs live wire of the brown, black & blue color to the power switch on the rear panel of cutting machine (no phase requirement), connect the earth cable of yellow & green color to the power cable input of cutting machine.

When the power supply voltage is over the safe work voltage, there are over voltage and under voltage protection inside the cutting machine, the alarm light will on, at the same time, the current output will be cut off.

If the power supply voltage continually goes beyond the safe work voltage range, it will shorten the cutting machine life-span. The below measures can be used:

- Change the power supply input net. Such as, connect the cutting machine with the stable power supply voltage of distributor;

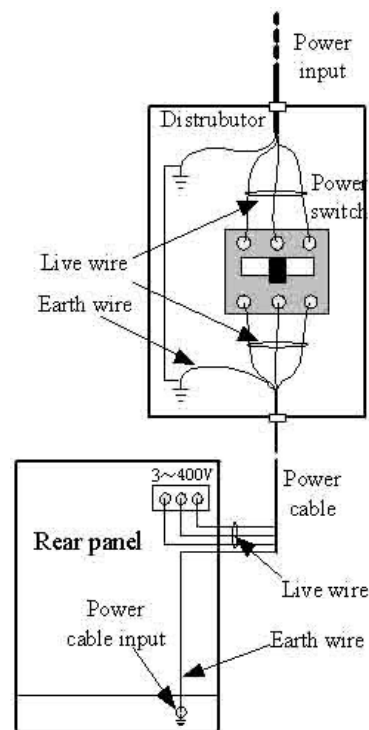

The connect method of the main supply

- Induce the machines using power supply in the same time;
- Set the voltage stabilization device in the front of power cable input.

§4.3 Gas Connections

1. Connecting Gas Supply to Unit

Connect the gas line to the inlet port of the gas filter on the rear panel.

2. Check Air Quality

To test the quality of air, press down the air check button, check if there are any oil or moisture in the air.

§5 Operation

§5.1 Cutting Preparation

- 1) Tightly connect the power cable to electrical socket outlet (the input voltage, refer to the section 2 technology parameters).
- 2) To connect the gas line to the air supply equipment, the earth cable to the workpiece.
- 3) Turn on the power switch, the screen is on.
- 4) Press the trigger mode button to select 2T or 4T trigger mode.
- 5) Regulate the air pressure to 3.5~6 bar.
- 6) Regulate the current after the flow stops as your requirement.
- 7) Now all the preparation done.

§5.2 Cutting Operation

1. Normal Cut

OPERATION

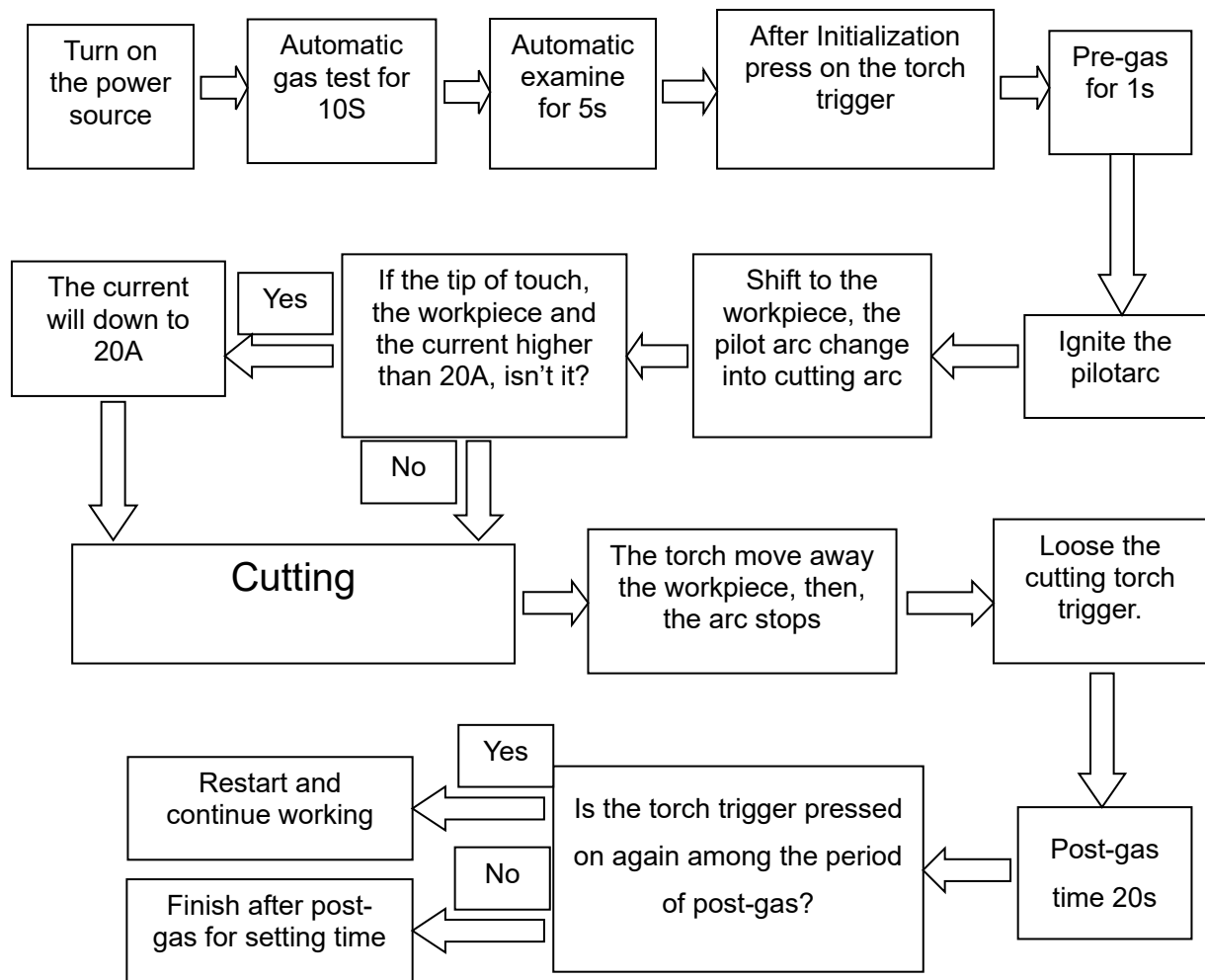

Note:

- 1) If the alarm appears on the screen when cutting, it is needed to loose the switch of the gun until the alarm release, then press on the switch to restart working.
- 2) In the automatic gas test and examine, press on the cutting gun, there will no reflection.
- 3) After a long usage, the surface of the electrode and nozzle will have oxidation reaction. Please replace the electrode and nozzle, For The alarm indicator will on when install the shield cup, and stop working
- 4) Among the period of post gas, if you press the trigger for a long time, the arc restart; if you press and loosen the trigger quickly, the gas stops, after it you can press the trigger for a long time to restart the machine as well.

2. Account for the alarm indicator:

- 1) When the machine appears over-heat, the screen will display error code “E01 Overheat”.



Over-heat: The alarm will release after the period of fan cooling. You can restart the machine.

- 2) When the air pressure is too lower, the screen will display error code “E12 Lack of gas”.



- 3) When the gas distributor is un-installed only, there is not alarm while operating the machine, and when you press the trigger, there is no arc and no load as well. Open the torch and check it.
- 4) The product uses three-phase input voltage. If the input voltage is short of phase, the machine will not work properly, and the following alarm will appear.



- 5) If the cutting gun is not properly connected to the machine or the cutting gun is faulty, and the following alarm will appear.

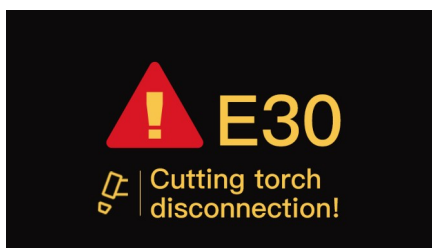

§5.3 About the CUT voltage divider

The CUT power supplies are equipped with an optional, factory-installed, four-position voltage divider that is designed to be safely connected without tools. The built-in voltage divider provides a scaled down arc voltage of 20:1, 30:1, 40:1, and 50:1 (maximum output of 18 V). An optional receptacle on the rear of the power supply provides access to the scaled down arc voltage and signals for arc transfer and plasma start.

Note:

The factory presets the voltage divider to 20:1. To change the voltage divider to a different setting, refer to the section on the next page.

	<p>The factory-installed internal voltage divider provides a maximum of 18V under open circuit conditions. This is an impedance-protected functional extra low voltage (ELV) output to prevent shock, energy, and fire under normal conditions at the machine interface receptacle and under single fault conditions with the machine interface wiring. The voltage divider is not fault tolerant and ELV outputs do not comply with safety extra low voltage (SELV) requirements for direct connection to computer products.</p>
---	---

Note:

The cover on the machine interface receptacle prevents dust and moisture from damaging the receptacle when not in use. This cover should be replaced if damaged or lost.

Installation of the machine interface cable must be performed by a qualified service technician. To install a machine interface cable:

1. Turn OFF the power and disconnect the power cord.
2. Remove the machine interface receptacle's cover from the rear of the power supply.
3. Connect the machine interface cable to the power supply.

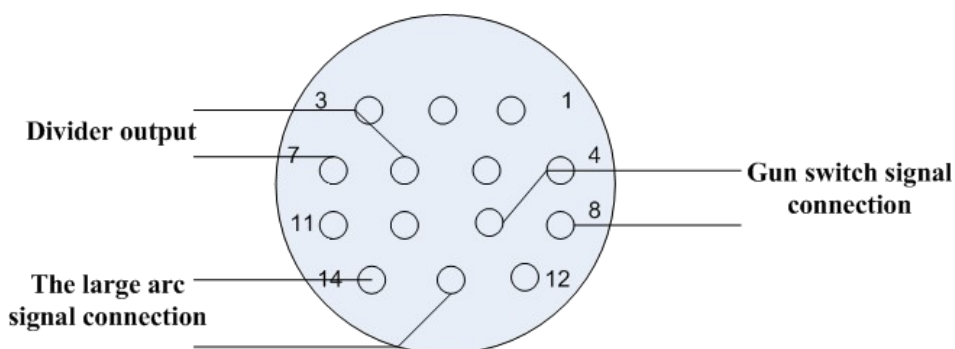

Refer to the following table when connecting the CUT system to a torch height controller or CNC controller with a machine interface cable.

signal	type	Instruction	Connector socket	Cable ends
Start (start plasma)	Input	Normally open. 18 VDC open circuit voltage at START terminals. Requires dry contact closure to activate.	8、 9	8 (yellow)、 9 (green)
Transfer(start machine motion)	Output	Normally open. Dry contact closure when the arc transfers. 120 VAC/1 A maximum at the machine interface relay or switching device (supplied by the customer).	13、 14	13 (blue)、 14 (white)
Voltage divider	Output	CUT: Divided arc signal of 20:1, 30:1, 40:1, 50:1 (provides a maximum of 18 V).	6 (+)、 7 (-)	6 (red)、 7 (black)

Setting the five-position voltage divider on the CUT

The factory presets the voltage divider to 20:1. To change the voltage divider to a different setting:

1. Turn OFF the power supply and disconnect the power cord.
2. Remove the power supply cover.
3. Locate the voltage divider DIP switches on the left side of the power supply.

Note: the table below for the shift and scale selection

Scale selection Dial number	20:1	30:1	40:1	50:1
1	ON	1	1	1
2	2	ON	2	2
3	3	3	ON	3
4	4	4	4	ON

CNC control cable selectable type:

Number	Standard (m)
6.310.660	5
6.310.660-D	10
6.310660-E	15

§5.4 Operation Environment

- ▲ Height above sea level ≤ 1000 M.
- ▲ Operation temperature range: 14~104°F (-10 ~ +40°C).
- ▲ Air relative humidity is below 90%.
- ▲ Preferable site the machine some angles above the floor level does not exceed 15°.

- ▲ Protect the machine against high moisture, water and against direct sunshine.
- ▲ Take care that there is sufficient ventilation during welding. There must be at least 1-1/2" (38cm) free distance between the machine and wall.

§5.5 Operation Notices

- ▲ Read Section §1 carefully before starting to use this equipment.
- ▲ Ensure that the input is 400VAC, three-phase: 50/60Hz.
- ▲ Before operation, clear the working area. Do not watch the arc in unprotected eyes.
- ▲ Ensure good ventilation of the machine to improve duty cycle and life.
- ▲ Turn off power supply when the operation finished for energy consumption efficiency.
- ▲ When power switch shuts off protectively because of failure. Don't restart it until problem has been resolved. Otherwise, permanent damage could occur.
- ▲ In case of problems, contact your local dealer.

§6 Basic Trouble Shooting

§6.1 Basic Troubleshooting Guide

**WARNING**

There are extremely dangerous voltage and power levels present inside this unit. Do not attempt to diagnose or repair unless you have had training in power electronics measurement and troubleshooting techniques.

§6.1.1 Basic troubles

A. Turn on the machine, the screen light on, but both of the fan and the air control valve is no action.

1. Absent Phases. Please check the input lines, and connect it correctly.
2. The main board in the machine is break. Please ask the qualified technician to change it.

B. Turn on the machine, the screen display “E12 Lack of gas”.

Gas pressure is too low. Adjust the gas pressure to 65psi/4.5bar. The Barometer indicate to 0.45~0.5MPa.

C. Turn on the machine, the screen display “Overheat”.

1. Air flow blocked, check for blocked air flow around the unit and correct condition.
2. Fan blocked, check and correct condition.
3. The machine is over-heat, let it cool down for at least 5 minutes. Make sure the machine has not been operated beyond the Duty Cycle (refer to technology parameters in Section 2).
4. Input voltage over the normal range, choosing the proper voltage (refer to technology parameters in the Section).
5. Faulty components in the machine, return for repair or have qualified technician repair per Service Manual.

§6.1.2 Pilot arc troubles

A. Torch failed to ignite the arc when torch is triggered.

1. The shield cup is unfitted installation. Turn off the power source, install and screw it properly, then turn on the power source.
2. The Tip or electrode is unfitted installation. Turn off the power source, and install and screw shield cup properly, then turn on the power source.
3. Gas pressure is too high or too low, adjust it to proper state.
4. Faulty components in the machine, return for repair or have qualified technician repair per Service Manual.

B. Difficult igniting

1. The gas distributor is un-installed
2. Worn torch parts (consumables), shut off input power. Remove and inspect torch shield cup, tip, starter cartridge, and electrode. Replace electrode or tip if worn; replace starter cartridge if end piece does not move freely; replace shield cup if excessive spatter adheres to it.
3. The machine is in trouble. Please ask the qualified technician to check it and repair the machine.

C. The torch is triggered, but the pilot arc isn't change to the cutting pilot. The power indicator lights up; Gas flows; Fan operates.

1. It is inaccurate connection between torch and power supply, check the torch leads are properly connect to power supply.
2. Work cable not connected to work piece, or connection is poor, make sure that work cable has a proper connection to a clean and dry area of the workpiece.
3. Faulty components in the machine, return for repair or have qualified technician repair per Service Manual.
4. Faulty Torch, return for repair or have qualified technician repair it.

D. Arc shuts off during operation, and it will not restart when torch is triggered.

1. Power Supply is overheated, let unit cool down for at least 5 minutes. Make sure the unit has not been operated beyond Duty Cycle limit. Refer to Section 2 for duty

cycle specifications.

2. Gas pressure too low, check source for at least 65 psi/4.5 bar; adjust as needed.
3. Torch consumables worn, check torch shield cup, tip, starter element, and electrode; replace as needed.
4. Faulty components in unit, return for repair or have qualified technician repair per Service Manual.

§6.1.3 Cutting troubles

A. No gas flow; the screen light on; Fan operates

1. Gas pipe not connected or pressure is too low, check gas connections. Adjust gas pressure to proper setting.
2. Faulty components in the unit, return for repair or have qualified technician repair.

B. Low cutting output

1. Incorrect setting of cutting current (A), check and adjust to proper setting.
2. Faulty components in unit, return for repair or have qualified technician repair.

C. Torch can cut but the cutting quality is poor

1. Current (A) control set too low, increase current setting.
2. The torch move too fast across the workpiece, reduce cutting speed.
3. Excessive oil or moisture in torch, hold torch 1/8 inch (3 mm) from clean surface while purging and observe oil or moisture buildup (do not activate torch). If there are contaminants in the gas, additional filtering may be needed.
4. Lack of air pressure. Please check the air pressure and air flow, adjust it to the appropriate position.